

SERIE UPF-02

PORTABLE ULTRASONIC FLOWMETER FOR MULTIPLE MEASURES OF FLOW/ENERGY

- Ü UNIQUE ON THE MARKET
- Ü ENERGY METER FUNCTION
- Ü USB MEMORY DATA TRANSFER
- Ü ENTIRELY WATER PROOF IP65
- Ü BEST RELIABILITY
- Ü GREAT VERSATILITY



MAIN FEATURES

The newly sales released portable ultrasonic flowmeter UPF02 with integrated heat quantity measurement feature, not only measures flows, but with its multi-function capability, is a powerful tool in energy conservation management of heating and cooling systems. In recent years, fueled by the intense debate on controlling CO₂ emissions and concerns about global warming, there has been widespread activity related to reducing energy consumption. Heating and cooling systems of buildings and factories, as huge consumers of energy, are the immediate focus of efforts to improve energy efficiencies and this exacerbating demands for efficient operation and proper maintenance of facilities based on appropriate energy conservation diagnostics.

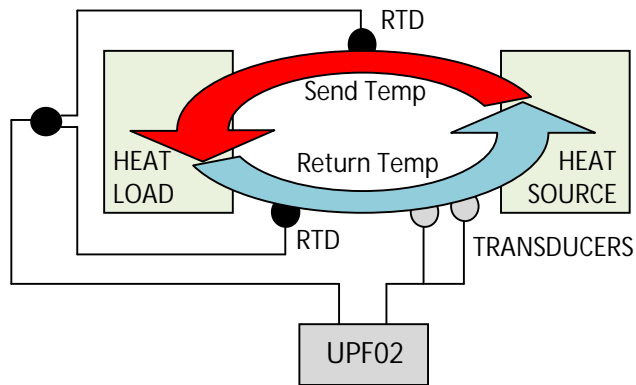

ENERGY METER FUNCTION

The UPF02 provides important functions demanded in heating and cooling system management, such as multi flow measurement (2 channels or 2 path) and heat energy measurement which are designed to meet the needs associated with construction, installation and maintenance. Also, it offers additional features which enhance ease of use, such as real-time waveform display monitoring of receiving echoes and inc operation, IP65 class dust and water protection rating.



APPLICATIONS

- § Hydraulic power plant.
- § Toluene storage tank outlet.
- § Flow measurement near valve position.
- § Pump station outlet.
- § Restricted space installation.
- § Chiller efficiency.
- § Ship engine coolant.
- § Return sludge line flow measurement.
- § Waste water inlet flow measurement.
- § Energy consumption verification.
- § Inspection tool for fire sprinkler.
- § Huge pipes.

VALCOM® PROFILE

Continuous improvement in Research & Development of quality products and new technologies based on over 35 years of experience, make Valcom® the right partner for the supply of instrumentation for the measure and control of level, pressure, temperature, flow, specific gravity and presence of liquids in Your industrial process.